



Ultra-Filtração

Tratamento Terciário de Águas Residuais

Serie W

Solução Fiável para, eficaz e baixa ocupação de espaço

- Compacto
- Modular
- Pronto a Ligar
- Robusto
- Fácil Manutenção
- De acordo com standards e normas Europeias
- Multifuncional
- Tecnologia inovadora
- Elevado rendimento

Inteligência no funcionamento, aplicação e eficiência de operação.

As unidades UF-W desenhadas e construídas pela GreatWater, são especialmente concebidas para o tratamento terciário de águas residuais, com vista à sua potencial reutilização.

Utilizam membranas capilares de 0,08 μm , para a remoção em particular dos seguintes elementos da água:

- Turbidez
- Bactérias e Vírus (> 4 Log)
- Sem *backwash*

Os sistemas UF-W, são desenhados e construídos pela GreatWater E&S e permitem dispor:

- ✓ Certificados NSF61
- ✓ Membranas de alta longevidade
- ✓ Operação simples
- ✓ Limpeza simples
- ✓ Alta recuperação
- ✓ Baixo custo de operação
- ✓ Facilidade de instalação
- ✓ Sistema compacto
- ✓ Equipamento auxiliar opcional

Units UF-W are designed and build to meet the requirements of waste water discharge regulations. Main objective of Series UF-W is to recycle water reducing discharge volumes and preserving the environment.

Uniquely designed hollow fiber membranes from 0,08 μm , to remove contaminants from surface and ground Water sources:

- Turbidity
- Bacteria and Vírus (> 4 Log)
- No backwash

The UF-W systems are designed and build by GreatWater E&S, to hollow:

- ✓ NSF61 Certification
- ✓ Long Service Life Hollow Fiber Membranes
- ✓ Operator Friendly Control Interface
- ✓ High Recovery
- ✓ Low Cost of Operation
- ✓ Easily Installed Modular Skids
- ✓ Compact System Footprint
- ✓ Optional Auxiliary Equipment





Ultra-Filtração

Tratamento Terciário de Águas Residuais

Serie W

HYDRAcap® MAX Operating Parameters

		Operating Range
Filtrate Flux, gfd (l/m ² /hr)		20 – 65 (34 – 110)
Filtrate Flow, gpm (m ³ /h)	HYDRAcap® MAX 4040	1.4 – 4.4 (0.3 – 1.0)
	HYDRAcap® MAX 40	7.5 – 24.4 (1.7 – 5.5)
	HYDRAcap® MAX 60	11.7 – 37.9 (2.7 – 8.6)
	HYDRAcap® MAX 80	15.7 – 51.0 (3.6 – 11.6)
Air scour flowrate, acfm (m ³ /hr)		7.3 – 9.1 (12.3 – 15.1)
Operating pH		4 – 10
Cleaning pH		1 – 13
Maximum Feed Turbidity, NTU		300*
Maximum Instantaneous Chlorine Tolerance, ppm		5,000
Total Chlorine Tolerance, ppm-hr		>750,000
Maximum Feed Pressure, psig (bar)		73(5)
Transmembrane Pressure (TMP), psig (bar)		1 -30 (0.07 – 2.0)

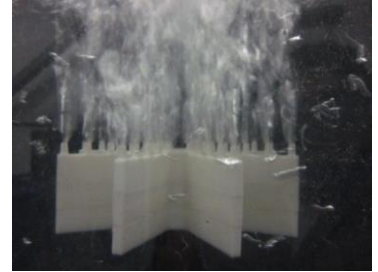

HYDRAcap® MAX Overview

Flow path	Outside to inside
Membrane material	PVDF
Filtration mode	Dead end or cross-flow
Membrane configuration	Hollow fiber
Membrane area*	97 ft ² (9 m ²) / 560 ft ² (52 m ²) / 840 ft ² (78 m ²) / 1130 ft ² (105 m ²)
Module Height*	45" / 54" / 72" / 92" (1.1 / 1.4 / 1.8 / 2.3 m)
Module Diameter	10" (250 mm)
Fiber ID/OD	0.6/1.2 mm
Pore size	0.08 µm (Ultrafiltration)
Physical cleaning mode	Air scour

As membranas Hydra-Cap Max, de elevada qualidade e desenhadas para utilização com águas carregadas, são a opção mais viável para o seu terciário e a reutilização de águas, permitindo reduzir os seus custos operacionais.

The Hydra-Cap Max and high quality design is suitable for use in waters with high solids content. The most viable solution for you tertiary treatment of your effluents and water re-use, reducing operational costs.

Diagrama de Processo para os sistema de ultra-filtração GreatWater

Process Flow Diagram for the Ultra-filtration GreatWater Units

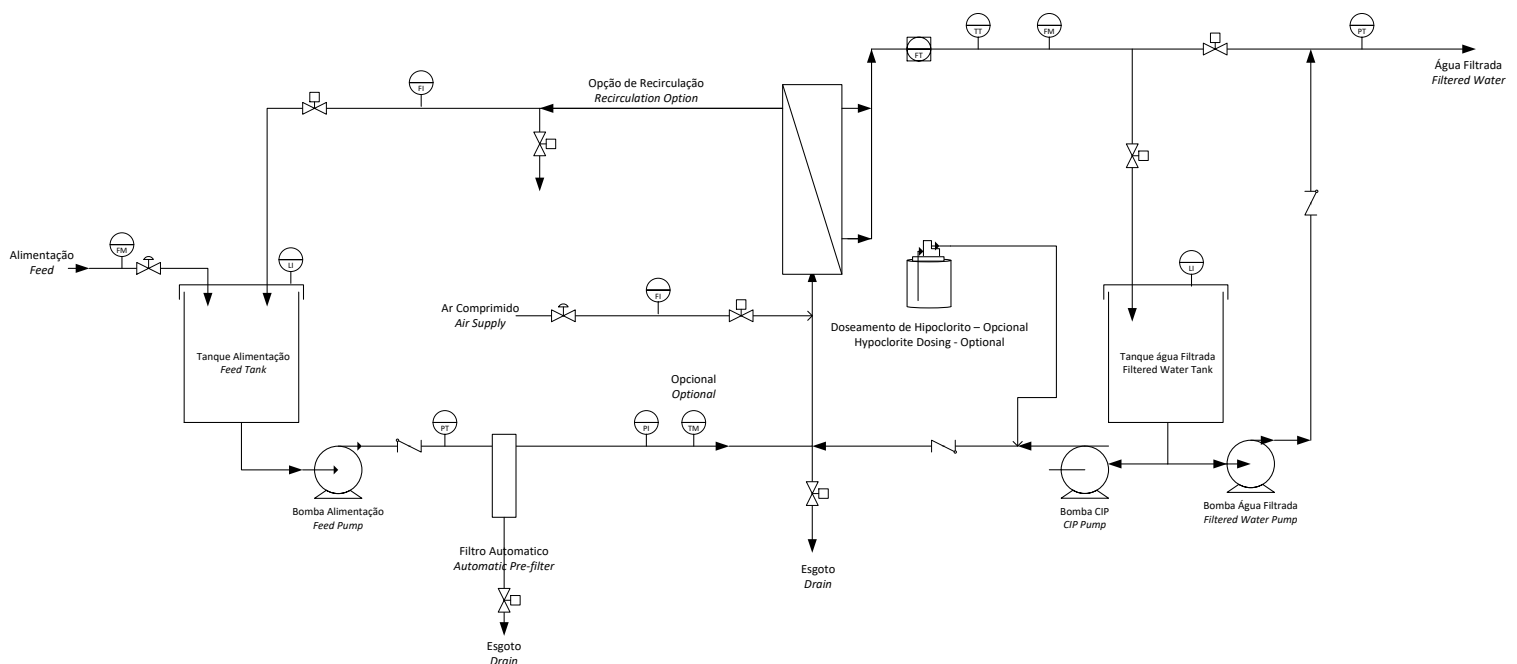

Visite-nos em / Visit us on
www.greatwater.pt

GreatWater E&S
 Rua do Zinco, Lote 104
 2950-007 Palmela, Portugal
 T: +351 212 360 629
 F: +351 212 385 363
 E: info@greatwater.pt
 W: www.greatwater.pt

Rua 5 de Julho
 Achada de São Filipe
 Praia, Cabo Verde
 T: +238 356 12 50
 E: info@aquexpertcv.com
 W: www.aquexpertcv.com



Equipment Made Easy